

REV.	ECN NO.	MODIFY MATTER	DATE	APPROVED
A		RELEASE TO PRODUCTION		

Remark:

- MATERIAL:
  - Housing:thermoplastic plastics.
  - terminals:Copper Alloy
  - Front Shell:Copper Alloy/SPCC.  
Middle Shell:SPCC
- characteristics:
  - Rating Voltage : 30V AC.
  - Rating Current:PIN1&PIN4(Vbus&Correponding ground PIN)  
1.8A MAX Other PINS 0.25A min.
  - Contact Resistance:PIN1&PIN4:30 mΩ MAX. Other PINS: 50 mΩ
  - Insulation Resistance:100 MΩ MIN.
  - Withstanding Voltage:AC 100V between adjacent contacts
- MECHANICAL CHARACTERISTIC:
  - INSERTION FORCE:35N MAX
  - EXTRACTION FORCE(INITIAL) : 10N MIN
  - EXTRACTION FORCE(AFTER TEST) :8N MIN
- The lifting weight of the product before durability is 10N Min. 3s

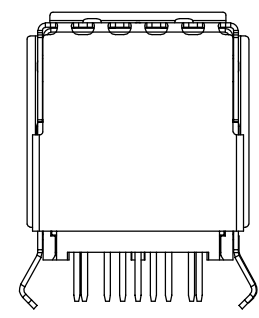
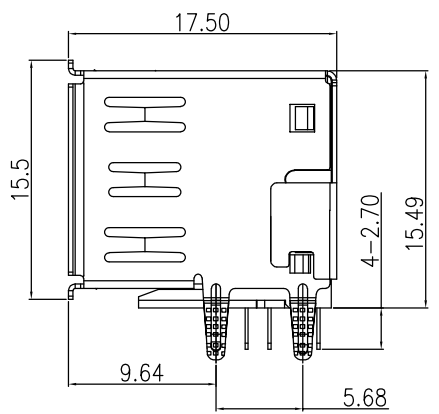
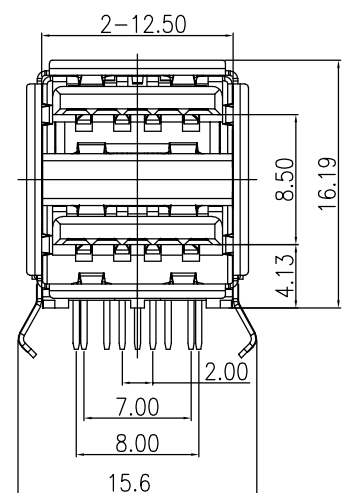
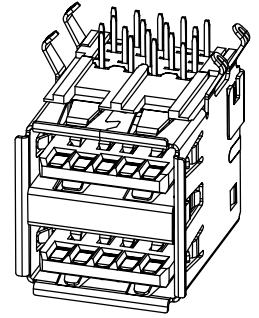
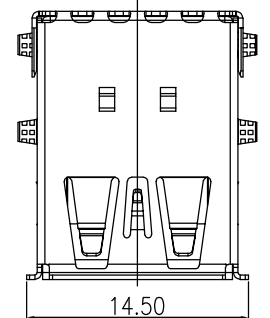

EAST-USB3D33S-1BBER

D: DIP  
S: SMT  
S: 铁壳镀镍  
C: 铜壳镀镍  
BK: 黑色  
BE: 蓝色300C  
P: PA66  
B: PBT  
1: 半金1u"  
8: 半金15u"  
L: LCP

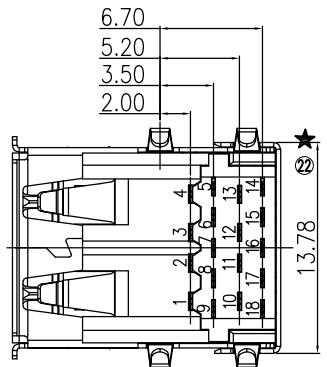
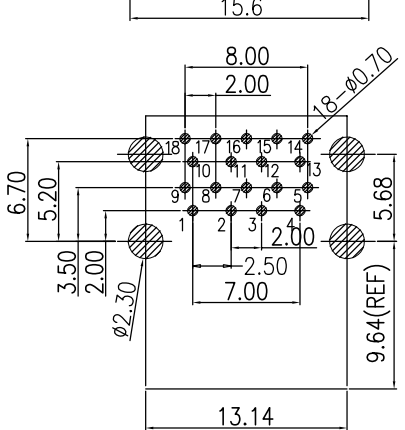

Pin Number	Signal Name	Pin Number	Signal Name
1	VBUS	10	VBUS
2	D-	11	D-
3	D+	12	D+
4	GND	13	GND
5	Std_SSRX-	14	Std_SSRX-
6	Std_SSRX+	15	Std_SSRX+
7	GND_DRAIN	16	GND_DRAIN
8	Std_SSTX-	17	Std_SSTX-
9	Std_SSTX+	18	Std_SSTX+
Shell	Shield		

TOLERANCES UNLESS OTHERWISE SPECIFIED: X. --- X.X ± 0.38 X.XX ± 0.25 X.XXX ± 0.10 Angle ± 1°		CUSTOMER COPY		<b>深圳市东方御业科技有限公司</b> WWW.DFYCONN.COM TEL:0755-27155560	
DRAWN: CHENLEI		2022/09/10		TITL: USB 3.0 AF双层90度短体 (RoHS)	
CHECKED: CHENLEI		2022/09/10		PART NO: EAST-USB3D33S-1BBER	
APPROVED: QINKAIXING		2022/09/10		UNIT: mm	
THESE DRAWING AND SPECIFICATION ARE THE PROPERTY OF Shenzhen Dongfangyue ELECTRONIC CO., LTD.. SHALL NOT BE REPRODUCED.		SCALE: N/A		SHEET: 1:1	

WWW.DFYCONN.COM

REV.	ECN NO.	MODIFY	MATTER	DATE	APPROVED
A		RELEASE TO PRODUCTION			

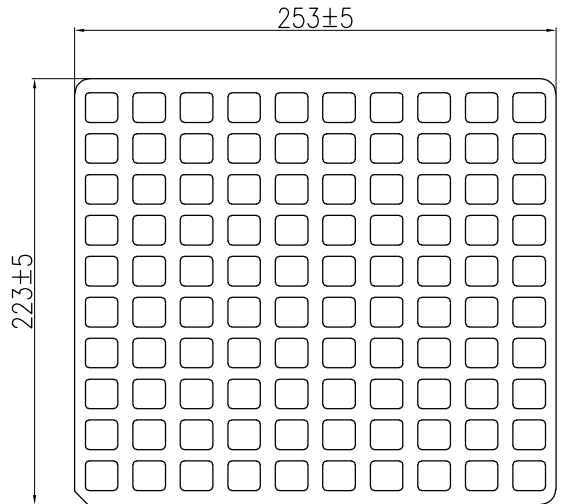

吸塑盒底盘

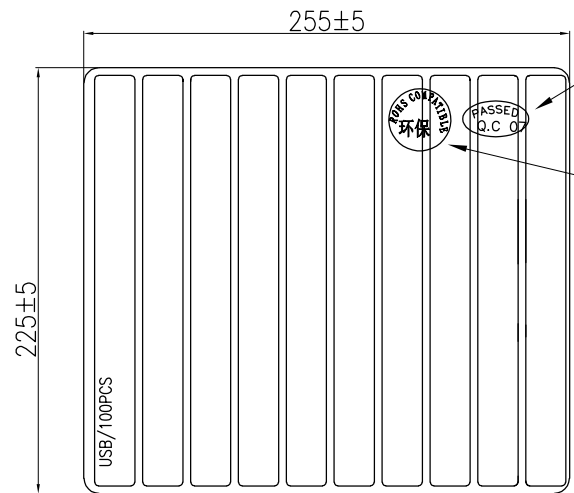

吸塑盒上盖

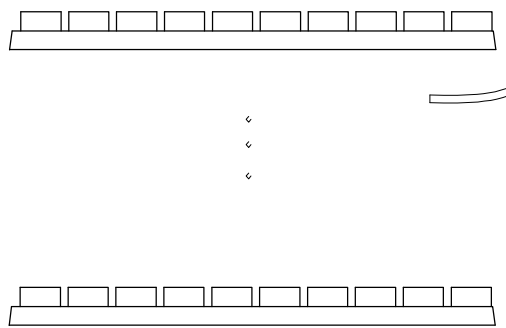
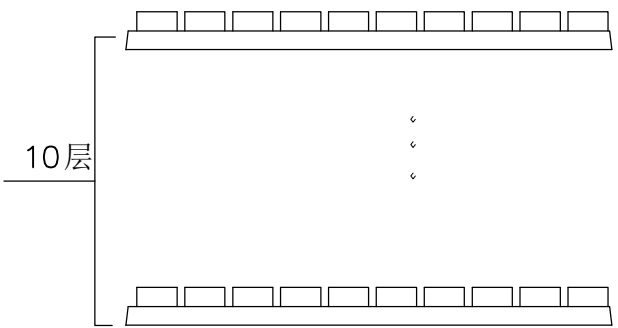

每箱放两排，每排10层，每箱装2000PCS

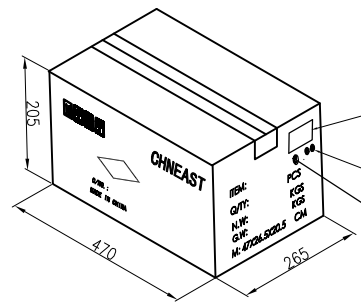
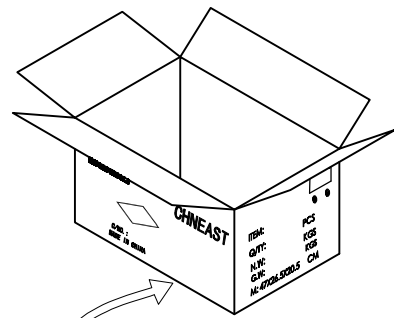

适用产品:

1. USB2.0 AF双层90度半包无弹系列
2. USB3.0 AF双层90度短体系列

包装要求:

1. 将全检后的良品如图示摆入规格为 25.5\*22.5cm的pvc透明吸塑盒中，每盒包装100pcs，摆好后，盖好上盖，并在右上方贴上pass标签。
2. 将装好产品的吸塑盒放入规格为 470\*265\*205mm的纸箱中，每箱放20盒，每箱装2000pcs
3. 用透明胶封好纸箱，并在纸箱右上角贴上对应产品标签. 然后在外箱标签右下方印上合格章. 外壳为铜时加贴铜标
4. 客户有特殊要求时按客户要求要求进行
5. 月份标签按月份标签粘贴作业规范进行
6. 出客户A175（康冠）的产品需在内部加贴环保标签，外箱不贴环保标，吸塑盘无需打订。

PASS标签  
环保标签 (出A175需加贴环保标签)

产品标签  
合格章，加盖于标签右下方  
外壳为铜时加贴铜标签  
同时内部每盘右上角加贴小铜标

TOLERANCES UNLESS OTHERWISE SPECIFIED: X. --- X.X ± 0.38 X.XX ± 0.25 X.XXX ± 0.10 Angle ±1°	COSTOMER COPY		深圳市东方御业科技有限公司 WWW.DFYCONN.COM TEL:0755-27155560		
	DRAWN: CHENLEI	2022/09/10	TITIAL: USB AF双层USB无弹包装规范 (RoHS)		
THESE DRAWING AND SPECIFICATION ARE THE PROPERTY OF Shenzhen Dongfangyuye ELECTRONIC CO., LTD.. SHALL NOT BE REPRODUCED.	CHECKED: CHENLEI	2022/09/10	PART NO: EAST-USB3D33S		
	APPROVED: QINKAIXING	2022/09/10	UNIT: mm	SCALE: N/A	SHEEL: 1:1