

REV.	ECN NO.	MODIFY MATTER	DATE	APPROVED
A		RELEASE TO PRODUCTION		

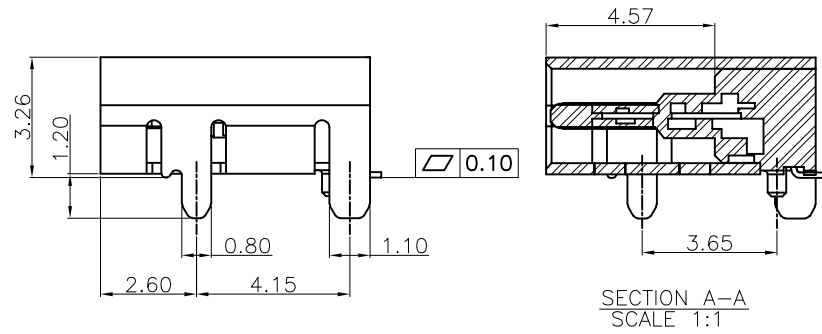

- NOTES:  
SPECIFICATION:
- CURRENT RATING: 5A MAX
  - VOLTAGE: 100 VAC
  - TEMPERATURE RANGE: -30 °C ~ 85 °C
  - CONTACT RESISTANCE: 40 MILLIONHM MAX
  - INSULATION RESISTANCE: 100 MEGOHMS MIN.
  - INSERTION FORCE : 5N~20N
  - UNMATING FORCE: 8N~20N
  - DURABILITY: 10,000 CYCLES
  - P/N EAST-UTC16SD730-X

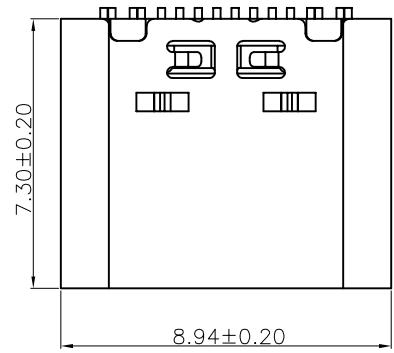
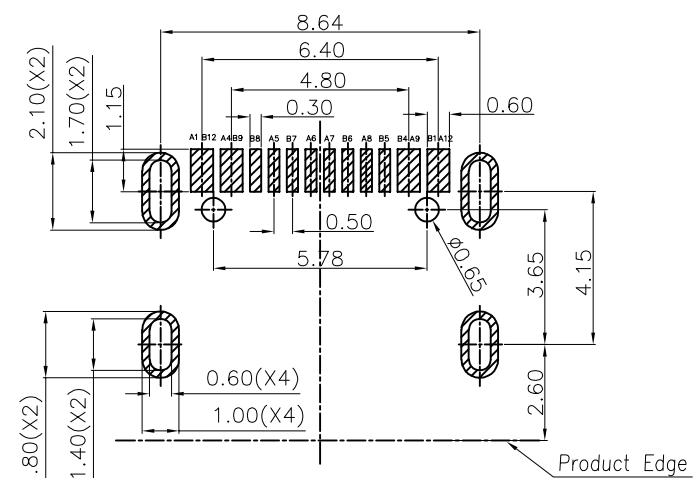
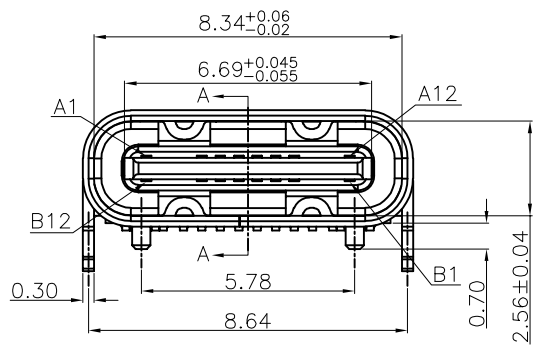

RECOMMENDED P.C.B. LAYOUT  
TOLERANCE UNSPECIFIED ±0.05mm

- A: Plating
- G01-gold flash in contact area And solder area.
  - G03-03u" gold in contact area And solder area.
  - G05-05u" gold in contact area And solder area.
  - G15-15u" gold in contact area And solder area.
  - G30-30u" gold in contact area And solder area.

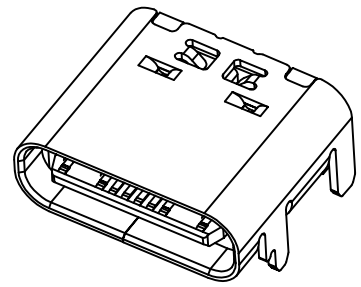
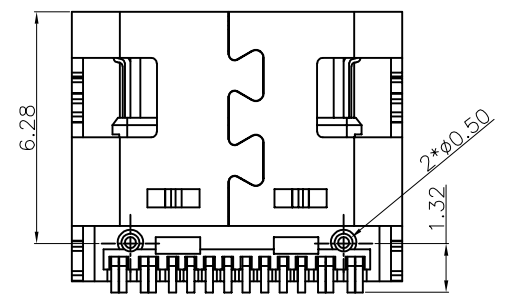

NO.	DESCRIPTION	MATERIAL	REMARK
4	SHIELDING PLATE	STAINLESS STEEL	----
3	SHELL	STAINLESS STEEL	NI Palated
2	TERMINAL	HIGH CONDUCTIVITY COPPER	Au 1u"
1	HOUSING	HIGH TEMPERATURE PLASTIC	UL 94V-0

A1	GND	B12	GND
A4	VBUS	B9	VBUS
A5	CC1	B8	SBU2
A6	DP1	B7	DN2
A7	DN1	B6	DP2
A8	SBU1	B5	CC2
A9	VBUS	B4	VBUS
A12	GND	B1	GND
PIN	SIGNAL NAME	PIN	SIGNAL NAME

TOLERANCES UNLESS OTHERWISE SPECIFIED: X. --- X.X ± 0.38 X.XX ± 0.25 X.XXX ± 0.10 Angle ± 1°		COSTOMER COPY		<b>深圳市东方御业科技有限公司</b> <b>WWW.DFYCONN.COM TEL:0755-27155560</b>	
DRAWN: CHENLEI		2017/09/10		TITL: USB 3.1 TYPE C 母座 板上型L=7.30mm 16Pin 3次 Molding 头部不露端子 有柱 (RoHS)	
CHECKED: CHENLEI		2017/09/10		PART NO: EAST-UTC16SD730-X	
APPROVED: QINKAIXING		2017/09/10		UNIT: mm	SCALE: N/A
THESE DRAWING AND SPECIFICATION ARE THE PROPERTY OF Shenzhen Dongfangyue ELECTRONIC CO., LTD. SHALL NOT BE REPRODUCED.				SHEET: 1:1	REV.

www.dfyconn.com

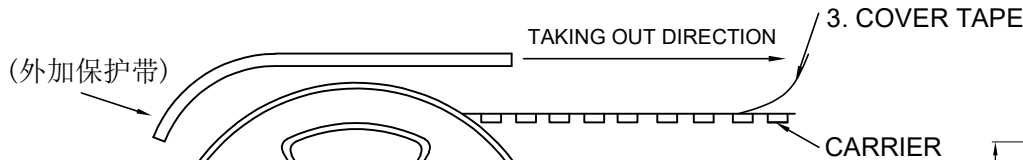

小标签格式

订单号	
品名	
料号	
数量	
重量	
生产日期	
订单号	
QC签名/盖章	
月份标签	

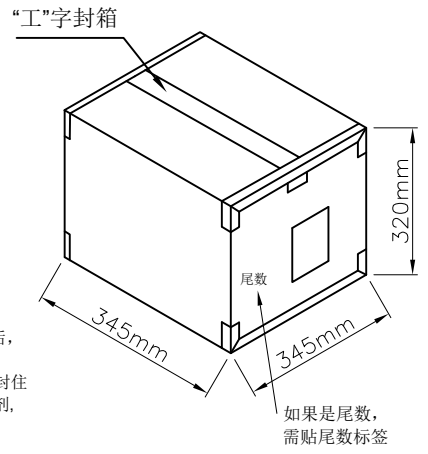
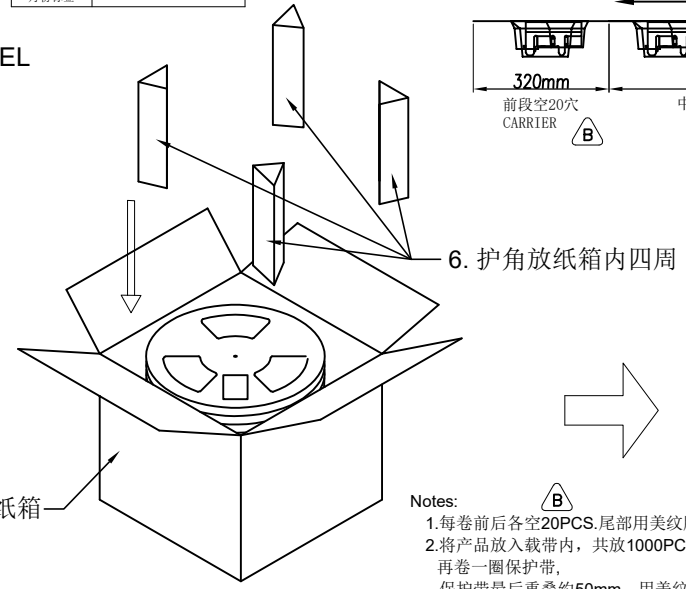
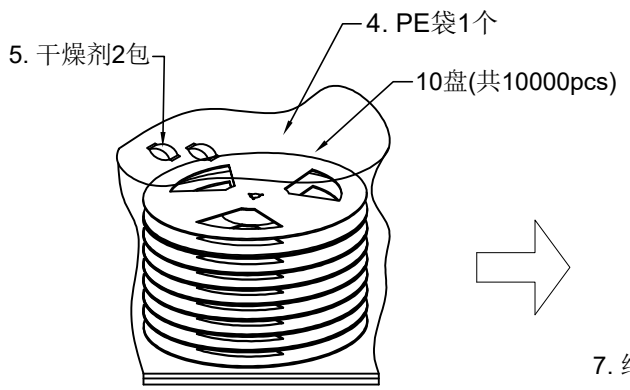
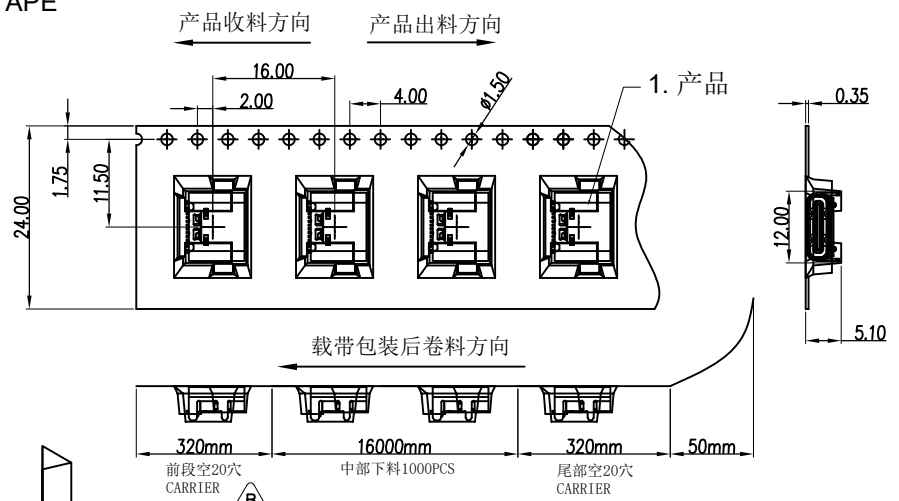

7	纸箱	双坑K=K 345*345*320mm	1PCS
6	三角柱	30.5*29cm	4PCS
5	干燥剂	—————	2PCS
4	PE袋	71*79.5cm	1PCS
3	COVER TAPE	21.0mm (自粘带)	若干
2	REEL	24.0mm (黑色载带)	10R
1	产品	—————	1K/R
序号	品名	规格(mm)	用量(PCS)

每卷数量	每箱数量	净重	毛重
1KPcs/Reel	10KPcs/Box	5kg	9.12kg

- Notes:
- 每卷前后各空20PCS.尾部用美纹胶纸封住,
  - 将产品放入载带内, 共放1000PCS,放满盘后,再卷一圈保护带, 保护带最后重叠约50mm, 用美纹胶纸将其封住
  - 每10卷盘装入一个防水袋, 再放入2包干燥剂, 然后放入1个外箱内; 纸箱内四周放护角;
  - 在搬运过程中要轻拿轻放.
  - 在运输中不可堆放过多,不可有重压现象.
  - 跌落测试条件:  
成品箱子从1.5米高自由落体(三棱六面一角)检验项目:  
1.产品不可跑出下带凹槽.  
2.产品不可有摔伤,变形.  
3.外箱及内包装材料不可严重破损.

TOLERANCES UNLESS OTHERWISE SPECIFIED: X. ——— X.X ± 0.38 X.XX ± 0.25 X.XXX ± 0.20 Angle ± 3°	INSPECTION COPY	深圳市东方御业科技有限公司 WWW.DFYCONN.COM TEL:0755-27155560		
	DRAWN: chenlei	2013/02/05	TITLE: USB 3.1 TYPE C 母座 板上型L=7.30mm 16Pin 3次 Molding 头部不露端子 有柱 包装示意图	
THESE DRAWING AND SPECIFICATION ARE THE PROPERTY OF Shenzhen dongfangyue CO.,LTD. SHALL NOT BE REPRODUCED.	CHECKED: qinkx	2013/02/05	PART NO: EAST-UTC16SD730-X	
	APPROVED: qinkx	2013/02/05	UNIT: mm	SCALE: N/A SHEEL: 1/1 REV: A