

| REV. | ECN NO. | MODIFY MATTER | DATE | APPROVED |
|------|---------|-----------------------|------|----------|
| A | | RELEASE TO PRODUCTION | | |

NOTES:

- ELECTRONIC:**
CONTACT RESISTANCE: 30mohm MAX
INSULATION RESISTANCE: 1000 Mohm MIN
WITHSTAND VOLTAGE:AC 500V,1min.
- MECHANICAL:**
DURABILITY: 5000 CYCLE.
- ENVIRONMENT CHARACTERISTICS:**
OPERATING TEMPERATURE:-55°C TO +105°C
- RECOMMANDER PCB THICKNESS 1.2 TO 1.60MM**
5. 标标“▲”符的的尺寸为重点检验尺寸;
- MATERIAL LIST:**

| No. | PART NAME | QTY | MATERIAL | REMARK |
|-----|-----------|-----|------------------|---------------|
| 3 | SHELL | 1 | STAINLESS SUS201 | NI PLATED |
| 2 | CONTACT | 9 | COPPER ALLOY | AU/TIN PLATED |
| 1 | HOUSING | 1 | PA9T BLUE | (UL 94V-0) |

EAST-USB2H42630PXX1R

- 1: 铁壳镀镍
- 2: 铜壳镀镍
- 3: 不锈钢

| XX | Housing Color |
|----|---------------|
| BK | Black |
| BE | Blue |

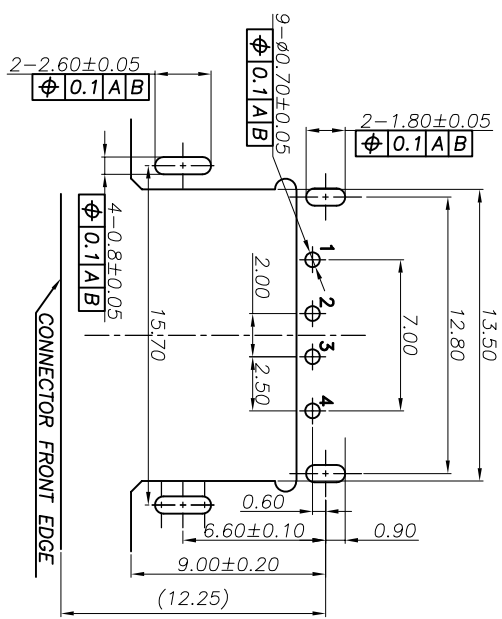
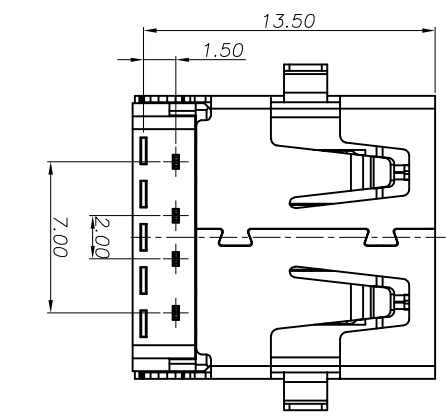
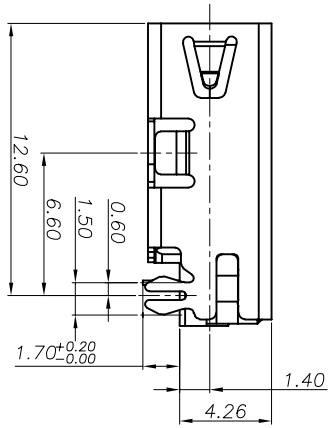
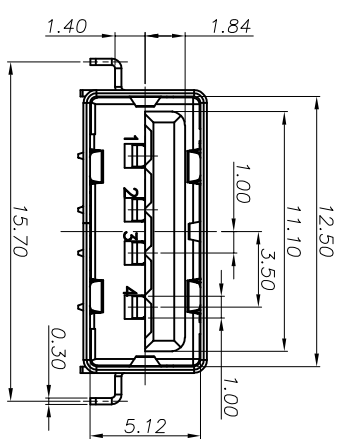
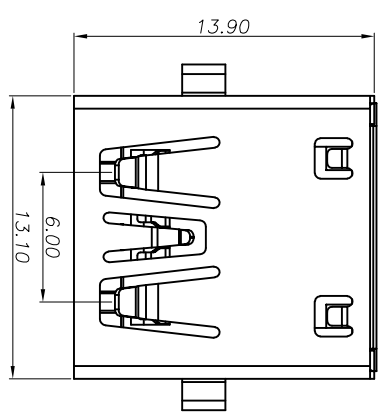
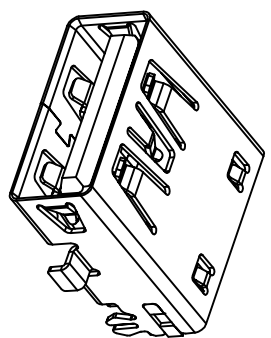

RECOMMENDED PCB LAYOUT

THESE DRAWING AND SPECIFICATION ARE THE PROPERTY OF SHENZHEN DONGFANG ELECTRONIC CO., LTD. SHALL NOT BE REPRODUCED

TOLERANCES UNLESS OTHERWISE SPECIFIED:
X, X.X ± 0.38
X.XX ± 0.25
X.XXX ± 0.10
Angle ± 1°

| | | | |
|-----------------------|------------------|------------------|---------------------------------------|
| DESIGNED: CHENLEI | CHECKED: CHENLEI | DATE: 2017/09/10 | PART NO.: EAST-USB2H42630PXX1R (R&H5) |
| APPROVED: QINXIAOXING | DATE: 2017/09/10 | SCALE: N/A | SHEET: 1/1 |

深圳市东方御业科技有限公司
WWW.DFYCONN.COM TEL: 0755-27155560

USB 2.0 AF R&A DIP L13.70 H4.46
CH=1.70

| REV. | ECN NO. | MODIFY MATTER | DATE | APPROVED |
|------|---------|-----------------------|------|----------|
| A | | RELEASE TO PRODUCTION | | |

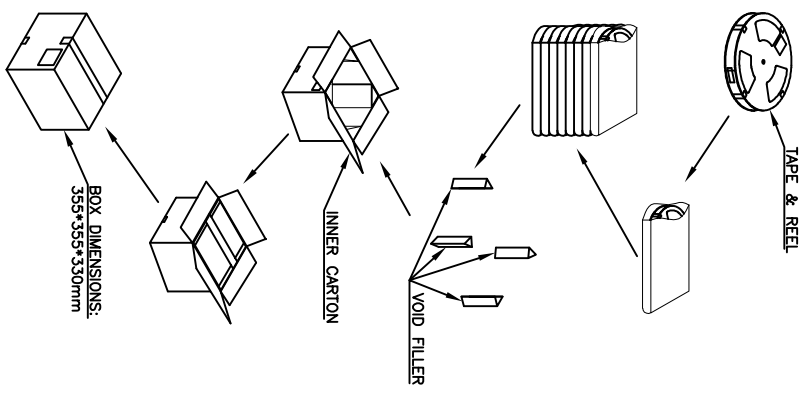
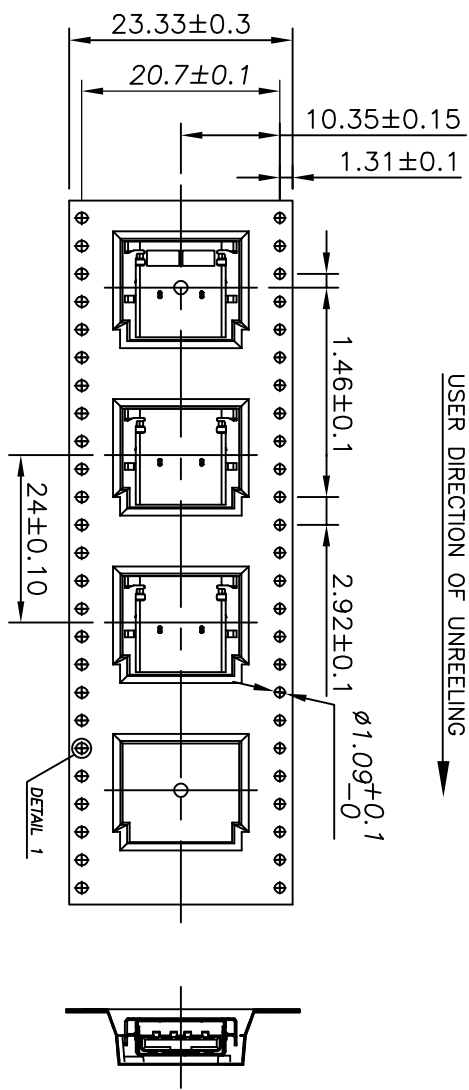
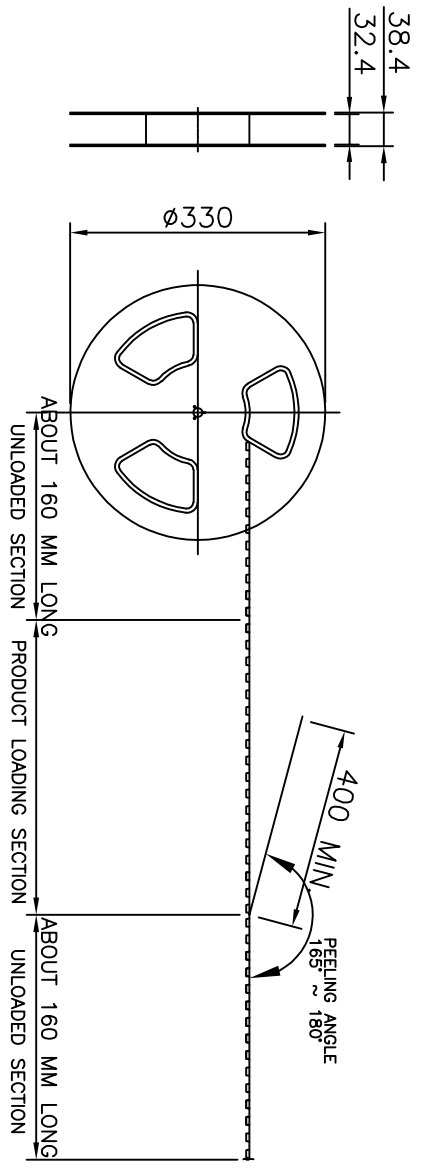

- NOTE:
- MATERIAL: BOX: FIBREBOARD, CORRUGATED, DOUBLE WALL
TAPE: POLYSTYRENES, HEAT-RESISTANT TEMPERATURE: 120°C, BLACK COLOR.
REEL: POLYSTYRENES, HEAT-RESISTANT TEMPERATURE: 70°C, BLUE COLOR.
BAG: POLYETHYLENE, HEAT-RESISTANT TEMPERATURE: 100°C.
 - PEELING SPEED: 0.1 ~ 1.3 N (10 ~ 130 GRAMS)
 - PEELING SPEED: 300 mm/min.
 - EACH BAG SHALL BE INCLUDED DESICCANT.

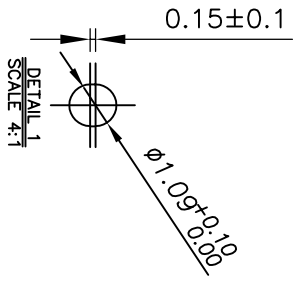

| PCS/ REEL/ CARTON | 10 | 4000 PCS | -- KG | NET WEIGHT |
|-------------------|----|----------|-------|------------|
| REEL | | | | |

TOLERANCES UNLESS OTHERWISE SPECIFIED:
 X, X.X ± 0.38
 X.XX ± 0.25
 X.XXX ± 0.10
 Angle ± 1°

CUSTOMER COPY
 DRAWN: CHENLEI
 CHECKED: CHENLEI
 APPROVED: QINMAIXING
 DATE: 2017/09/10

THESE DRAWING AND SPECIFICATION ARE THE PROPERTY OF Shenzhen Dongfeng Electronic Co., Ltd. SHALL NOT BE REPRODUCED.

深圳市东方御业科技有限公司
 WWW.DFYCONN.COM TEL: 0755-27155560

PART NO.: EAST-
 USB3.0 AF FEMALE 90度 DIP (RHS)

DATE: 2017/09/10
 SCALE: N/A
 SHEET: 1:1