

RECOMMENDED PCB LAYOUT

- NOTES:
- 1.ELECTRONIC:
    - CONTACT RESISTANCE: 30mohm MAX
    - INSULATION RESISTANCE: 1000 Mohm MIN
    - WITHSTAND VOLTAGE:AC 500V,1min.
  - 2.MECHANICAL:
    - DURABILITY: 5000 CYCLE.
  - 3.ENVIRONMENT CHARACTERISTICS:
    - OPERING TEMPERATURE:-55°C TO +105°C
  - 4.RECOMMANDER PCB THICKNESS 1.2 TO 1.60MM
  5. 标注“▲”符号的尺寸为重点检验尺寸;
  - 6.MATERIAL LIST:

No.	PART NAME	QTY	MATERIAL	REMARK
3	SHELL	1	STAINLESS SUS201	NI PLATED
2	CONTACT	9	COPPER ALLOY	AU/TIN PLATED
1	HOUSING	1	PA9T BLUE	(UL 94V-0)

EAST-USB309L3N12263-BE

X	Terminal Plating
0	Au 1u" Plating
1	Au 3u" Plating
2	Au 6u" Plating
3	Au 15u" Plating

XX	Housing Color
BK	Black
BE	Blue

USB 3.0 PIN ASSIGNMENTS

Pin #	SIGNAL NAME/DESCRIPTION	MATING SEQUENCE
1	VBUS	POWER
2	D-	USB 2.0 DIFFERENTIAL PAIR
3	D+	THIRD
4	GND	GROUND FOR POWER RETURN
5	Stda_SSRX-	SECOND
6	Stda_SSRX+	DIFFERENTIAL PAIR
7	GND_DRAIN	GROUND FOR SIGNAL RETURN
8	Stda_SSTX-	SUPERSPEED TRANSMITTER DIFFERENTIAL PAIR
9	Stda_SSTX+	LAST
Shell	Shield	CONNECTOR METAL SHELL
		FIRST

TOLERANCES UNLESS OTHERWISE SPECIFIED:

X	± 0.38
X.X	± 0.25
X.XX	± 0.10
X.XXX	± 1°
Angle	

THESE DRAWING AND SPECIFICATION ARE THE PROPERTY OF SHENZHEN DONGFANG ELECTRONIC CO., LTD. 99% SHALL NOT BE REPRODUCED.

CUSTOMER COPY

深圳市东方御业科技有限公司  
WWW.DFYCONN.COM TEL:0755-27155560

DATE: 2017/09/10

PART NO: USB 3.0 AF R&A DIP 沉板BH4.26

CH1.40

EAST-USB309L3N12263-BE (R&H5)

APPROVED: QINXIAO

SCALE: N/A

SHEET: 1:1

REV.	ECN NO.	MODIFY MATTER	DATE	APPROVED
A		RELEASE TO PRODUCTION		

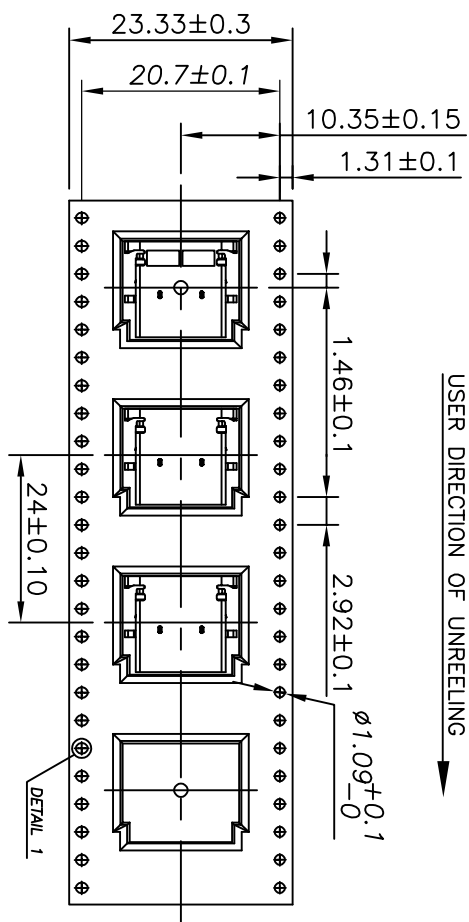
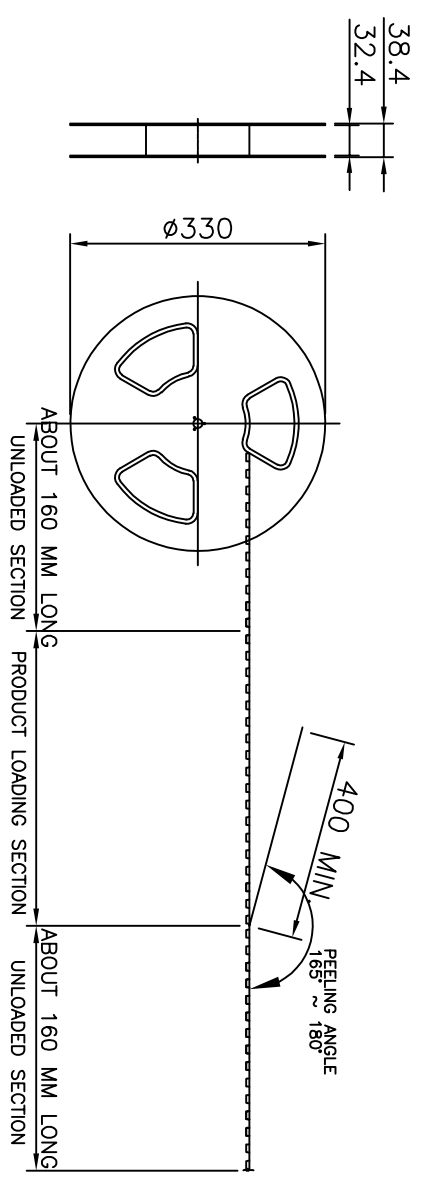

- NOTE:
- MATERIAL: BOX: FIBREBOARD, CORRUGATED, DOUBLE WALL  
TAPE: POLYSTYRENES, HEAT-RESISTANT TEMPERATURE: 120°C, BLACK COLOR.  
REEL: POLYSTYRENES, HEAT-RESISTANT TEMPERATURE: 70°C, BLUE COLOR.  
BAG: POLYETHYLENE, HEAT-RESISTANT TEMPERATURE: 100°C.
  - PEELING STRENGTH: 0.1 ~ 1.3 N (10 ~ 130 GRAMS)
  - PEELING SPEED: 300 mm/min.
  - EACH BAG SHALL BE INCLUDED DESICCANT.

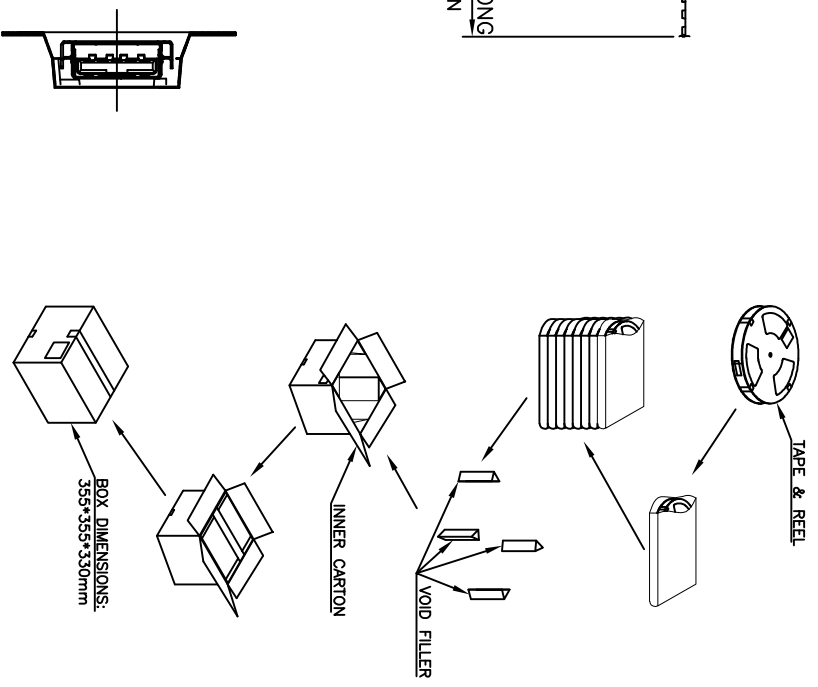

PCS/ REELS/ REEL	10	4000 PCS	-- KG	NET WEIGHT
CARTON				

深圳市东方御业科技有限公司  
 WWW.DFYCONN.COM TEL: 0755-27155560

TOLERANCES UNLESS OTHERWISE SPECIFIED:	X	± 0.38
X.X	± 0.25	
X.XX	± 0.10	
X.XXX	± 1°	
Angle		

THESE DRAWING AND SPECIFICATION ARE THE PROPERTY OF Shenzhen Dongfang Electronic Co., Ltd. SHALL NOT BE REPRODUCED.

CUSTOMER COPY	DATE: 2017/09/10
DRAWN: CHENLEI	CHECKED: CHENLEI
APPROVED: QINMAIXING	DATE: 2017/09/10

PART NO.: EAST-  
 USB3.0 AF FEMALE 90度 DIP (RHS)

8 7 6 5 4 3 2 1